

1. MECHANICAL DIMENSION

Product Dimension

Unit:mm	General Tolerance :	X.X : ± 0.38
		X.XX : ± 0.20

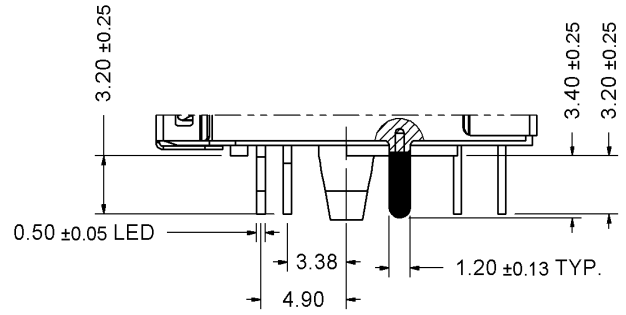
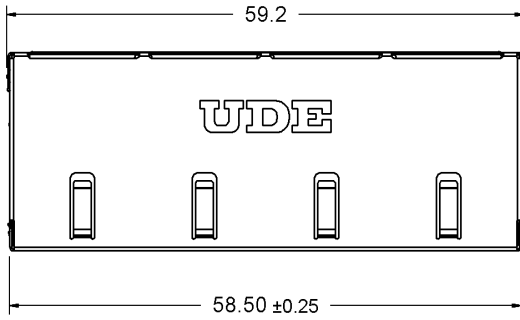

DETAIL A
Scale 2 : 1

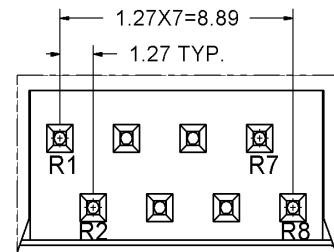
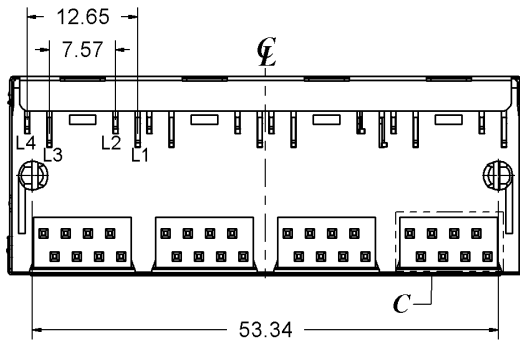
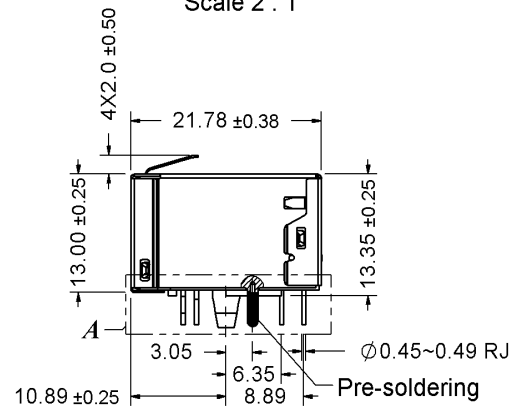
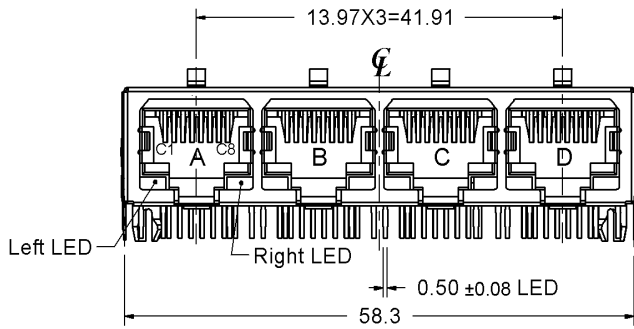

DETAIL C
Scale 3 : 1

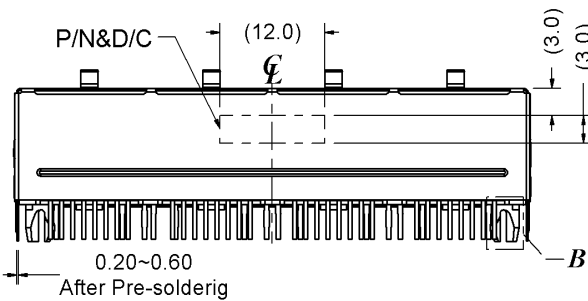

Back View

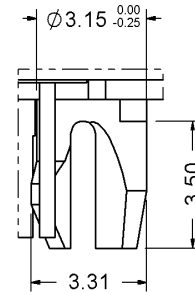

DETAIL B
Scale 4 : 1